

Analysis of hydraulic system for adjustable ground clearance mechanism

Jithendra Sai Raja CHADA, Venkat SANDEEP G, Rajesh CHOLLANGI

DOI: 10.30464/jmee.2020.4.3.203

Cite this article as:

Chada J. S. R., Sandeep G V., Chollangi R. Analysis of hydraulic system for adjustable ground clearance mechanism. Journal of Mechanical and Energy Engineering, Vol. 4(44), No. 3, 2020, pp. 203-208.

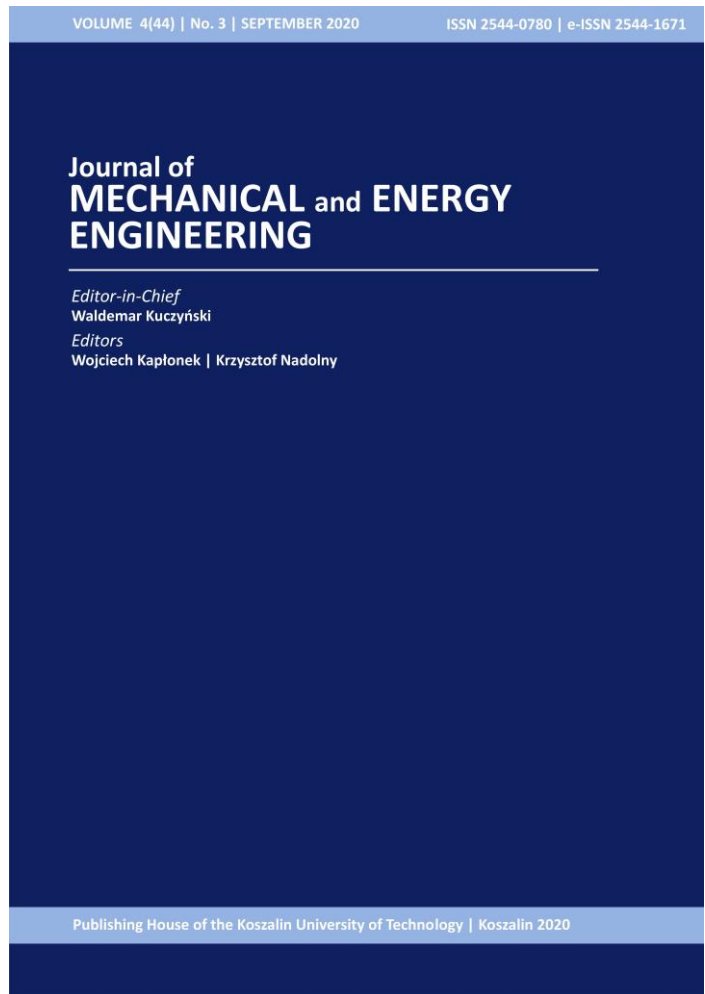

VOLUME 4(44) | No. 3 | SEPTEMBER 2020 ISSN 2544-0780 | e-ISSN 2544-1671

**Journal of
MECHANICAL and ENERGY
ENGINEERING**

Editor-in-Chief
Waldemar Kuczyński

Editors
Wojciech Kapłonek | Krzysztof Nadolny

Publishing House of the Koszalin University of Technology | Koszalin 2020

Journal of Mechanical and Energy Engineering

Website: jmee.tu.koszalin.pl

ISSN (Print): 2544-0780
ISSN (Online): 2544-1671
Volume: 4(44)
Number: 3
Year: 2020
Pages: 203-208

Article Info:
Received 10 September 2020
Accepted 23 September 2020

Open Access

This article is distributed under the terms of the Creative Commons Attribution 4.0 (CC BY 4.0) International License (<http://creativecommons.org/licenses/by/4.0/>), which permits unrestricted use, distribution, and reproduction in any medium, provided you give appropriate credit to the original author(s) and the source, provide a link to the Creative Commons license, and indicate if changes were made.

ANALYSIS OF HYDRAULIC SYSTEM FOR ADJUSTABLE GROUND CLEARANCE MECHANISM

Jithendra Sai Raja CHADA^{1*}, Venkat SANDEEP G.¹, Rajesh CHOLLANGI¹

^{1*}Department of Mechanical Engineering, Pragati Engineering College, Andhra Pradesh, India,
e-mail: csai0799@gmail.com

(Received 10 September 2020, Accepted 23 September 2020)

Abstract: The stability of a vehicle depends on many parameters. The Centre of Gravity is one of the most important in them. If the height of center of gravity from the ground decreases the stability of the vehicle increases. But when the ground clearance is too low it has a chance of collision vehicle and the ground while going on an uneven road or with speed brakes. So, to avoid the collision of a vehicle to ground and increase the stability a mechanism to adjust the ground clearance is to be attached. Also, the lift and drag forces can also be altered using this adjustable ground clearance mechanism. The designers usually fix ground clearance and they try to acquire this by the suspension system. The suspension system has tires, tire air, springs, shock absorber, and other parts to connect the vehicle with the wheels. The present paper describes the significance of using hydraulic oil as a working fluid in an adjustable ground clearance mechanism. Also describes the design and analysis of piston and cylinder rod.

Keywords: center of gravity, adjustable ground clearance, cylinder and cylinder rod, hydraulic oil

1. INTRODUCTION

Roads are not in the same condition everywhere. They may vary with climate, place, soil, other factors. At certain conditions road goes straight without any pits else we found irregularity. Most people buy only one four-wheeler which they use in all this condition. Hence it's necessary to give some standard ground clearance to the vehicle. But still, there is some obstruction while driving the car on the highway and in the city. To obtain good performance at high speed and low speed it is necessary to build one system which can vary the ground clearance. This can be achieved by changing the suspension height so that the chassis height can be adjusted concerning the speed and the quality of roads.

Ground clearance is the position of the vehicle body (sprung mass) above the basic ground level. It's an important parameter in an off-road vehicle. For a certain car's weight, there is a certain amount of mechanical downforce act on tires, and therefore the grip of tires is constantly changing during the running condition. The whole weight of the vehicle is concentrated at a point known as a center of gravity point. Ground clearance is a critical factor in several

important characteristics of a vehicle. For all vehicles, especially cars, variations in clearance represent a trade-off between handling and practicality. Higher ground clearance means that the center of mass of the car is higher, which makes for less precise and more dangerous handling characteristics (most notably, the chance of rollover is higher). However, it also means that the car is more capable of being driven on roads that are not level, without the road scraping against and likely damaging the chassis and underbody. Higher ride heights will typically adversely affect aerodynamic properties.

2. LITERATURE

Jagadeesh H *et al.*, have studied the working of adjustable ground clearance mechanism using an experimental setup. The mechanism is applied with different weights to find the working of adjustable ground clearance mechanism using pneumatic lifting. The ground clearance is adjusted without human effort [1]. Debojyoti Mitra *et al.*, have studied the lift and drag coefficients on adjustable ground clearance mechanism. It is cleared that as height increases the drag coefficient increases and lift coefficient decreases

[2]. Ghanshyam Baghel *et al.*, have studied the adjustable ground clearance mechanism using pneumatic lifting. It is stated that the initial cost of setup may be high but the maintenance cost may be low. It is also a user friendly mechanism to protect the vehicle from damage [3].

Kumar Mayank *et al.*, have studied the adjustable ground clearance mechanism using gear and tooth mechanism. It is concluded that the mechanism increases the performance and also this has better market potential [4]. Karl-Erik Rydberg *et al.*, have studied the hydraulic oil properties and its effect on energy efficiency. It has concluded that the energy efficiency is solely depends on the viscosity of oil [5]. Shivraj Chandrakant Patil *et al.*, have studied the adjustable ground clearance mechanism using a gear mechanism. It has concluded that the fuel efficiency can be altered by altering the ground clearance [6]. Krishan *et al.*, have designed and analyzed the hydraulic cylinder. It has concluded that the two stage cylinders reduce the maintenance of the system and damage [7].

Raju *et al.*, have studied the effect of holes on cylinder. It is clear that the cylinder without holes have shown better results [8]. Chada Jithendra Sai Raja *et al.*, have studied the significance of hydraulic oils as working fluids in hydraulic systems. It is stated that hydraulic oils are better option because of good lubrication property, good coolant, High corrosion resistance and resistance to cavitation [9]. Jagadamba Potnuru *et al.*, have designed and analyzed a three stage hydraulic system for dump trucks. It stated that hydraulic cylinder influences the work efficiency, reliability and the maintenance cost [10]. Shuan-qiang Xu *et al.*, have studied the Shakedown analysis of thick-walled cylinders subjected to internal pressure with the unified strength criterion. It is stated that the influence of the strength-difference is trivial when the wall ratio is small, whereas it is significant when the wall ratio is large [11].

J M Hale *et al.*, have studied the effect of Self-Weight Loading of Horizontal Hydraulic Cylinders with Axial Load. It is clear that load on the cylinder depends on angular misalignment [12]. Nedim Hodžić *et al.*, have studied the flow of hydraulic oil in a channel. It is decided that there is 6% variation in experimental to simulated results [13]. Stamatios S. Kalligeros *et al.*, have studied the maintenance actions on a hydraulic lifting system. The system is based on the viscosity of oil [14]. Mang, T *et al.*, have studied the hydraulic oils and stated that main purpose of hydraulic oil is to guide a moving part through smooth motion or rotation and simultaneously to reduce mechanical erosion [15]. To find the significance of using hydraulic oil as a working fluid in hydraulic hybrid vehicles. Also to design the cylinder and

cylinder rod arrangement of the hydraulic working system in adjustable ground clearance mechanism.

3. METHODOLOGY

Let the curb mass of car be 3000 kg with a capacity of 8 members. According to the league table of world fastest nations from the London school of hygiene and tropical medicine, average weight of human is 62 kg:

$$TW = CW + n \times W, \quad (1)$$

$$TW = 3000 + 8 \times 62, \quad (2)$$

$$TW = 3496 \text{ kg}. \quad (3)$$

The mass on the each wheel can be given by:

$$Rm = \frac{TW}{4}, \quad (4)$$

$$Rm = \frac{3496}{4}, \quad (5)$$

$$Rm = 874 \text{ kg}. \quad (6)$$

The weight on each wheel can be given by:

$$Rw = Rm \times g, \quad (7)$$

$$Rw = 874 \text{ kg} \times 9.81 \text{ m/s}^2, \quad (8)$$

$$Rw = 8573.94 \text{ N}. \quad (9)$$

According to the standard SAE rules and laws, the safety factor for the four wheeler relies on 3. In order to make the system safe to handle the load on each wheel is tripled. So the load on each wheel (R_{fos}) can be taken as 25721.82 N for the analysis of system.

As we are using hydraulic oils, the load on the walls of cylinder are in the form of pressure. So the load on cylinder can be calculated as:

$$P = \frac{R_{fos}}{A}, \quad (10)$$

$$P = \frac{Rw \times 3}{\frac{\pi}{4}d^2}, \quad (11)$$

$$P = 1536406.38 \text{ Pa}. \quad (12)$$

3.1. Material Selection

The hydraulic cylinders work under the most humid and continuous loading medium. The ideal properties required are good corrosion resistance as the working condition is humid, high strength to withstand continuous loading, low density to reduce weight, good machinability to manufacture, high thermal resistance as the components are sliding pairs.

Based on the above properties Al 5056 (Mg-5%, Mn-0.12%, Cr-0.12% and Balance Al) and Al 7075 (Zn-5.6%, Cu-1.6%, Mg-2.5%, Cr-0.23% and balance Al) are taken into consideration. The properties are as listed in Table 1.

Tab. 1. Properties of materials

Property	Al 5056	Al 7075
Density, kg/m ³	2640	2810
Modules of elasticity, GPa	71	72
Thermal expansion, °C	24.1×10 ⁻⁶	23.6×10 ⁻⁶
Thermal conductivity, W/mK	117	173
Tensile strength, MPa	414	572
Yield strength, MPa	345	503
Shear strength, MPa	221	331
Fatigue strength, MPa	152	159
Poisson's ratio, –	0.33	0.32

3.2. Design

The system consists of three components: Primary cylinder, Secondary cylinder and cylinder rod with 10 mm × 5 mm key way. The primary cylinder is connected to the wheels through an attachment. The Primary cylinder can give a ground clearance up to 100 mm. The secondary cylinder is activated when the pressure in the cylinder increases further. The combined primary and secondary cylinder with cylinder rod can give ground clearance up to 20 cm. The cylinder rod is used to pump the fluid into the cylinder as the holes on the cylinder may damage the cylinder faster. The design is carried out in CATIA V5.

Tab. 2. Dimensions of components in mm

Component	Internal diameter, mm	Outer diameter, mm	Length, mm
Primary cylinder	123.65	146.05	200
Secondary cylinder	95	123.65	160
Cylinder rod	25	95	300

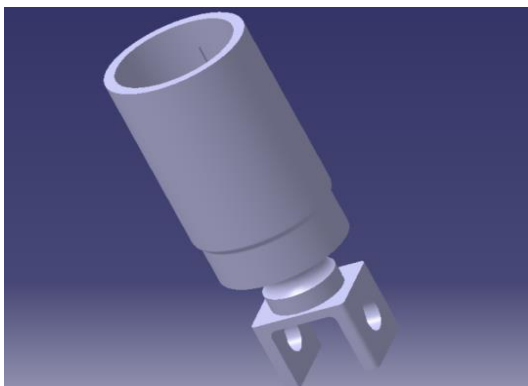

Fig. 1. CAD model of primary cylinder

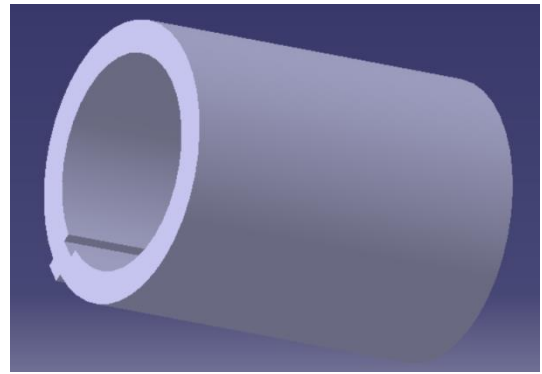

Fig. 2. CAD model of secondary cylinder

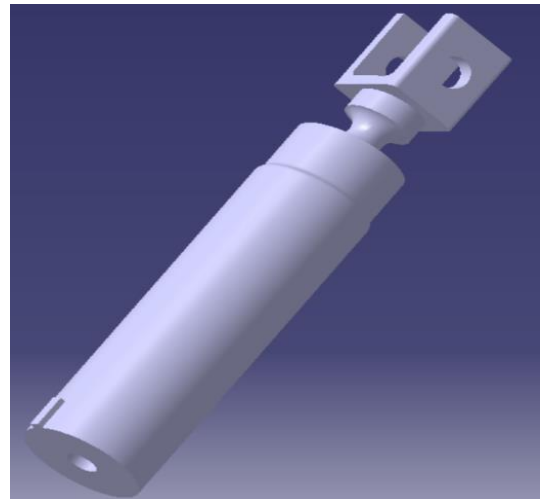

Fig. 3. CAD model of cylinder rod

4. SIGNIFICANCE OF HYDRAULIC OIL

The hydraulic oils have unique characteristics like less sensitivity of temperature to viscosity, show less expansion with a change in temperature, high chemical stability, offers the resistance to damage of sliding parts with lubrication property, acts as a good coolant, etc.

The selection of the grade of hydraulic fluid depends on the viscosity of the fluid. The object to select the hydraulic oil is to minimize the losses and maximize the performance.

5. RESULTS AND DISCUSSION

The pressure calculated is applied on the walls of cylinder to analyze the stress and deformation.

5.1. Results of components made of Al 5056

The internal pressure of 1536406.38 Pa is applied on each internal surface. From Fig. 4 to Fig. 9 we have seen the simulated results.

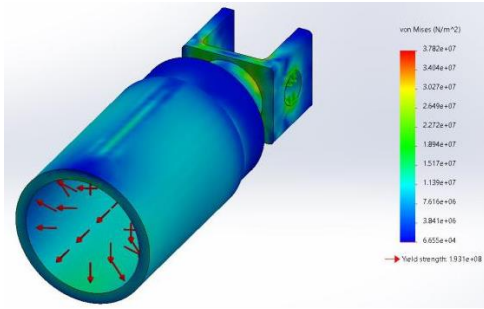

Fig. 4. Von Mises Stress in H1 with Al 5056

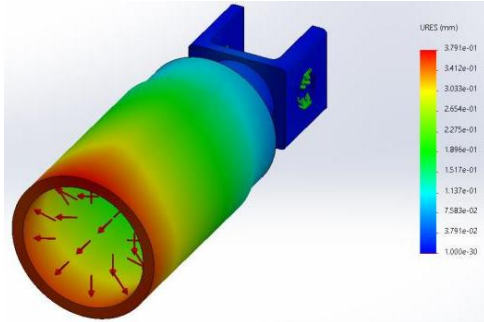

Fig. 5. Deformation in H1 with Al 5056

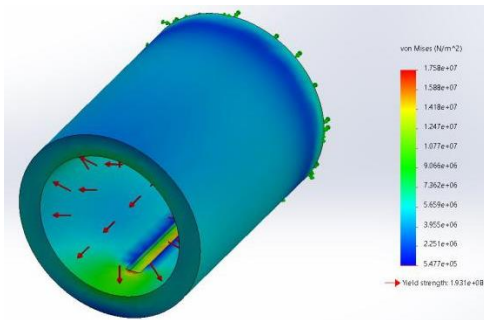

Fig. 6. Von Mises Stress in H2 with Al 5056

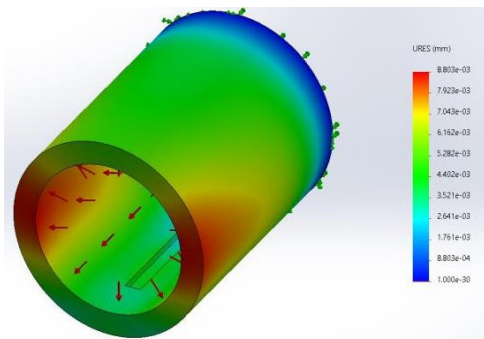

Fig. 7. Deformation in H2 with Al 5056

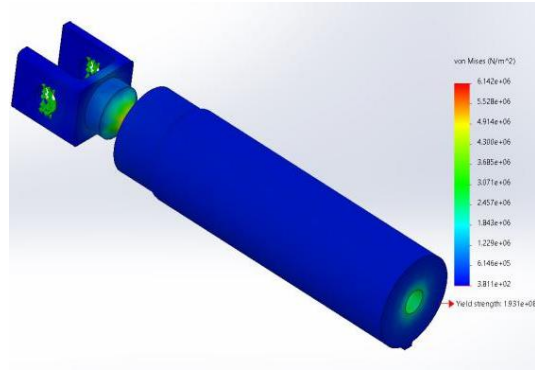

Fig. 8. Von Mises Stress in CR with Al 5056

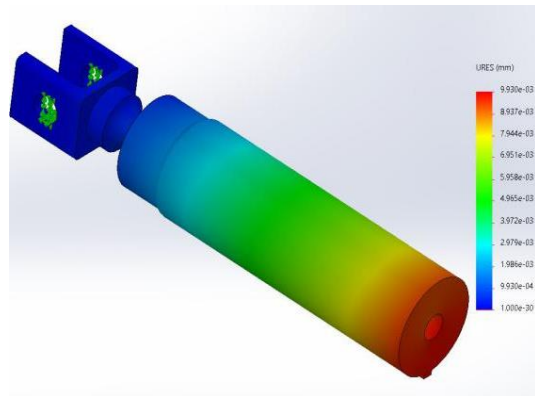

Fig. 9. Deformation in CR with Al 5056

The maximum stress zone in the cylinder is observed at the joint because the entire pressure is handled at that position. The max stress zone in the secondary cylinder is observed at the inner key way because the force from the primary cylinder and cylinder rod are acting on the key way passage. The cylinder rod is subjected to maximum force at the inner side because it holds maximum pressure to lift the vehicle.

Tab. 3. Results for Al 5056

	H1	H2	H3
Von Mises stress, N/m ²	3.782e+07	1.758e+07	6.142e+06
Deformation, mm	0.379	0.00887	0.00993

5.2. Results of Components made of Al 7075

The internal pressure of 1536406.38 Pa is applied on each internal surface.

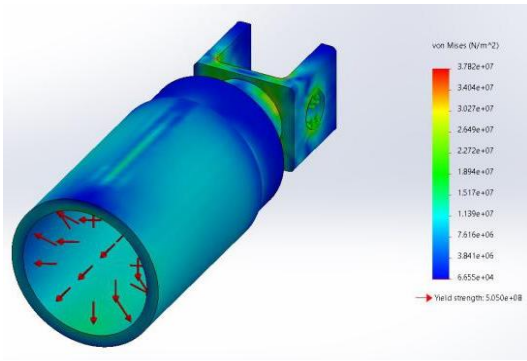

Fig. 10. Von Mises Stress in H1 made of Al 7075

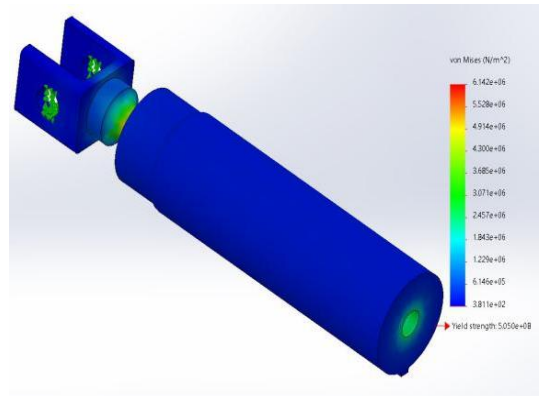

Fig. 14. Von Mises Stress in CR with Al 7075

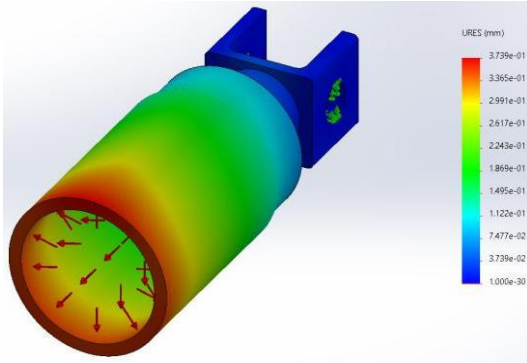

Fig. 11. Deformation in H1 with Al 7075

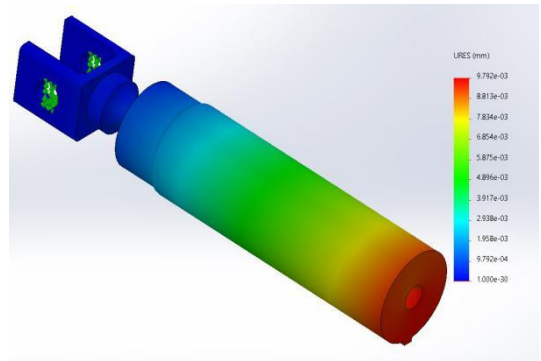

Fig. 15. Deformation in CR with Al 7075

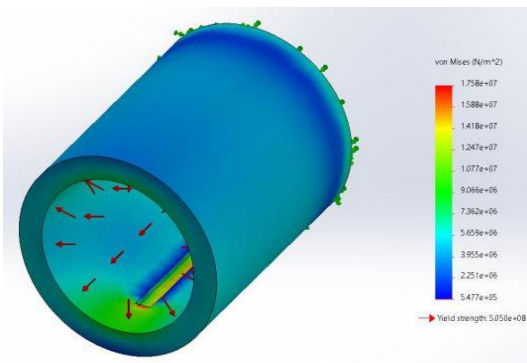

Fig. 12. Von Mises Stress in H2 with Al 7075

The Al 7075 has shown better values of stress and deformation as compared to the results from Al 5056.

Tab. 4. Results for Al 7075

	H1	H2	H3
Von Mises stress, N/m ²	3.782e+07	1.758e+07	6.142e+06
Deformation, mm	0.3739	0.00886	0.00972

6. CONCLUSION

The analysis has provided that the stress and deformation values of components with the considered materials. The values of stress and deformation have very little variation. The stress in H1, H2, CR are 3.782e+07 N/m², 1.758e+07 N/m², 6.142e+06 N/m² respectively, But the deformations are minimum for Al 7075 as 0.3739 mm, 0.00886 mm, 0.00972 mm respectively. The material Al 7075 is best suitable for the construction of the system. But in order to reduce the weight and cost of production Al 5056 is preferred because of its less density and low cost. However, we can't predict the performance directly from the Software results only. In the future the system may be modified with lighter and high strength materials or by changing the design of components.

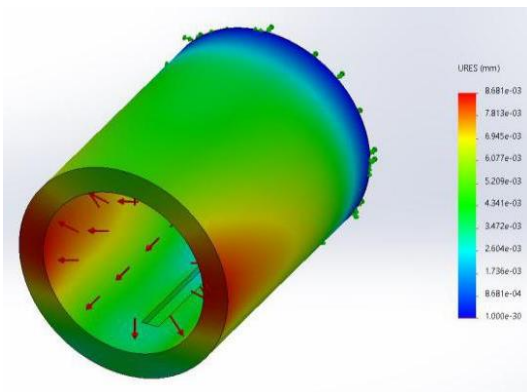

Fig. 13. Deformation in H2 with Al 7075

Nomenclature

Symbols

g	– acceleration due to gravity, m/s^2
n	– number of passengers
P	– pressure in cylinder, Pa
R_{fos}	– safety weight, N
R_m	– mass acting on each wheel, kg
R_w	– weight on each wheel, N

Acronyms

CR	– cylinder rod
CW	– curb weight, kg
H1	– primary cylinder
H2	– secondary cylinder
TW	– total weight of vehicle, kg

References

- Jagadeesh H. , Navinesh B.C. (2018). Development of Advanced Pneumatic Lifting and Ground Clearance Technique in Car . *International Journal of Innovative Research in Science, Engineering and Technology*, Vol. 7, No. 7, pp. 378-383.
- Debojyoti Mitra (2010). Design Optimization of Ground Clearance of Domestic Cars. *International Journal of Engineering Science and Technology*, Vol. 2, No. 7, pp. 2678-2680.
- Ghanshyam Baghel, Prince Jaiswal, Prashant Dewangan, Abhishek Parsend, Devesh Shrivastava (2017). Adjustable Ground Clearance in Vehicles Using Pneumatic Lifting. *International Journal of Science, Engineering and Technology Research* Vol. 6, No. 6, pp. 1075-1081.
- Kumar Mayank, Diwanshu Sharma, Gowreesh (2017). Adjustable Ground Clearance System by using Gear and Tooth Mechanism. *International Journal of Science Technology & Engineering*, Vol. 4, No. 3, pp.21-26.
- Karl-Erik Rydberg (2013). Hydraulic Fluid Properties and their Impact on Energy Efficiency. The 13th Scandinavian International Conference on Fluid Power, SICFP2013, June 3-5, 2013, Linköping, Sweden, pp. 447-453.
- Shivaraj Chandrakant Patil (2016). Adjustable Ground Clearance Mechanism. 5th International Conference On Recent Trends In Engineering, Science and Management, ICRTSM-16, Dec 9-10, 2016, Pune, pp. 1204-1210.
- Krishan, Dr. Pradeep Kumar Soni (2019). Minimisation of maintenance actions through design analysis of hydraulic cylinder for trailer. *International Research Journal of Engineering and Technology*, Vol. 6, No. 3, pp. 3944-3948.
- G. Raju, K. Hari Babu, N. Siva nagaraju, K.Kiran chand (2015). Design and analysis of Stress on Thick Walled Cylinder with and with out Holes. *Int. Journal of Engineering Research and Applications*, Vol. 5, No. 1, pp. 75-83.
- Chada Jithendra Sai Raja, Mahboob Shaheen, Dwarampudi Ramya Sudha, Vankala Nagababu (2019). Significance Of Using Hydraulic Oil As Working Fluid In Hydraulic Hybrid Vehicles. *International Journal of Engineering Applied Sciences and Technology*, Vol. 4, No. 4, pp. 115-118.
- Jagadamba Potnuru, Hari Sankar Vanka (2015). Design and Optimization of Three Stages Hydraulic Cylinder Used In Dump Trucks. *International Journal & Magazine of Engineering, Technology, Management and Research*, Vol. 2, No. 11, pp. 271-276.
- Shuan-qiang Xua, Mao-hong Yua (2005). Shakedown analysis of thick-walled cylinders subjected to internal pressure with the unified strength criterion. *International*

Journal of Pressure Vessels and Piping, Vol. 82, pp. 706-712.

- J.M. Hale, Ee Yu Sim (2016). *Journal of Physics: Conference Series*, Vol. 721, 012006.
- Nedim Hodžić, Nermina Zaimović-Uzunović, Boris Trogrlić (2006). Numerical analysis of hydraulic oil flow through channels and chambers of the cylindrical piston valve. 10th International Research/Expert Conference "Trends in the Development of Machinery and Associated Technology" TMT 2006, Barcelona-Lloret de Mar, Spain, pp. 1039-1042.
- Stamatios S. Kalligeros (2014). Predictive Maintenance of Hydraulic Lifts through Lubricating Oil Analysis. *Machines*, Vol. 2, pp. 1-12.
- Mang, T., Dresel, W. *Lubricants and Lubrication*, 2nd ed.; Wiley-VCH Verlag GmbH & Co. KGaA: Weinheim, Germany, 2007, pp. 274–337

Biographical notes



Jithendra Sai Raja Chada is an under graduate student pursuing his Bachelor's Degree (BTech) in Mechanical Engineering at Pragati Engineering College. He has published 7 papers in referred international journals. His current research interests include CFD, Industrial Design, Nano Materials, Manufacturing Processes, Heat Transfer, Additive Manufacturing, Advanced Machining, Energy Recovery Systems.



Venkat Sandeep G is an under graduate student pursuing his Bachelor's Degree (BTech) in Mechanical Engineering at Pragati Engineering College. His Current research interests are CAD Industrial Design.



Rajesh Chollangi has been working as a professor at Pragati Engineering College, Andhra Pradesh, India. He received Ph.D in Mechanical Engineering from Jawaharlal Nehru Technological University, Hyderabad in 2018. He has 22 years of experience in teaching and industry. He published 6 papers in referred international and national journals & 12 conference papers. His current research interests include structural analysis, Design, Vibration control, smart materials.