

# Classification of elements in the diagnostic model of a technical object for building an expert knowledge base

Stanisław DUER, Laszlo POKORADI, Dariusz BERNATOWICZ, Radosław DUER

---

**Online:** [http://www.jmee.tu.koszalin.pl/download\\_article/jmee\\_2017\\_01\\_071078.pdf](http://www.jmee.tu.koszalin.pl/download_article/jmee_2017_01_071078.pdf)

## Cite this article as:

Duer S., Pokoradi L., Bernatowicz D., Duer R. Classification of elements in the diagnostic model of a technical object for building an expert knowledge base. *Journal of Mechanical and Energy Engineering*, Vol. 1(41), No. 1, 2017, pp. 71-78.

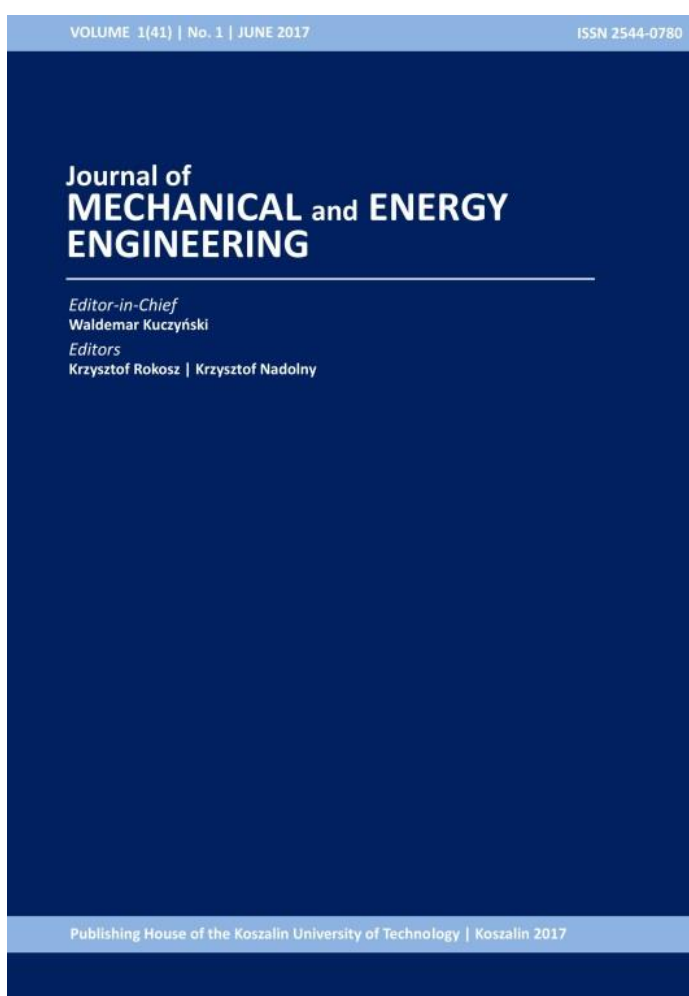

**Journal of Mechanical and Energy Engineering**

**ISSN (Print):** 2544-0780

**ISSN (Online):** 2544-1671

**Volume:** 1(41)

**Number:** 1

**Year:** 2017

**Pages:** 71-78

## Article Info:

Received 23 March 2017

Accepted 12 May 2017

## Open Access

This article is distributed under the terms of the Creative Commons Attribution 4.0 (CC BY 4.0) International License (<http://creativecommons.org/licenses/by/4.0/>), which permits unrestricted use, distribution, and reproduction in any medium, provided you give appropriate credit to the original author(s) and the source, provide a link to the Creative Commons license, and indicate if changes were made.

# CLASSIFICATION OF ELEMENTS IN THE DIAGNOSTIC MODEL OF A TECHNICAL OBJECT FOR BUILDING AN EXPERT KNOWLEDGE BASE

Stanisław DUER<sup>1\*</sup>, Laszlo POKORADI<sup>2</sup>, Dariusz BERNATOWICZ<sup>3</sup>, Radosław DUER<sup>3</sup>

<sup>1\*</sup> Faculty of Mechanical Engineering ,Department of Energy Engineering , Koszalin University of Technology, 15-17 Raclawicka St., 75-620 Koszalin, Poland, e-mail: stanislaw.duer@tu.koszalin.pl

<sup>2</sup> Faculty of Mechanical and Safety Engineering, Institute of Mechatronics and Vehicle Engineering, Óbuda University, Budapest, H-1081 Budapest, Népszínház u. 8, e-mail: pokoradi.laszlo@bkg.uni-obuda.hu

<sup>3</sup> Faculty of Electronics and Informatics, Department of Informatics, Koszalin University of Technology, 2 Śniadeckich St., 75-453 Koszalin, Poland, e-mail: ruder@wp.pl; dariusz.bernatowicz@tu.koszalin.pl

*(Received 23 March 2017, Accepted 12 May 2017)*

**Abstract:** The following paper presents the problem of classification (identification) elements in the internal structure of a technical object. This problem is directly linked with diagnostics and compilation of an expert data base. The basis of a process of grouping elements into classes is to make a diagnostic model of a given object in a form of a structure or set of basic elements of an object. In order to conduct the grouping of elements into subsets of s-th classes, the following paper compiles and presents analytical formulas and classification rules. Theoretical considerations presented in this paper are also verified using an engine control system as an example of a complex technical object.

**Keywords:** expert systems, diagnostic systems, expert knowledge base, technical diagnostic, algorithm, artificial intelligence.

## 1. INTRODUCTION

Development of technical diagnostics of devices and technical objects can be consider via development of issues directly connected with the process of diagnosis. Among the problems contributing to the development of diagnostics we can distinguish: functional-diagnostic analysis of a diagnosed object, modeling of a technical object, measurement and analysis of the diagnostic signal properties, diagnostic reasoning – recognition of state of a diagnosed technical object. The problems concerning description of methods and procedures of functional-diagnostic analysis of a diagnosed object are widely available in bibliography. Significant papers in this field are the following [4-7]. The purpose of functional-diagnostic analysis of an object is to determine the set of diagnostic information. This set is presented in a form of rational and optimal set of basic elements and diagnostic signals that are basis of diagnostics of a given object. A set of these signals must be optimal in order to make diagnostics of a given object reliable.

Authors of this paper systematically improved their specialist workshop, including experience in the field of research and analysis of internal structure of technical objects in order to acquire diagnostic information to organize the process of object diagnosis.

In recent years we can observe an intensive development of technical objects like planes, radiolocation systems, state-of-the-art power grids (wind farms) and other technical devices. Mentioned devices and technical systems are technical solutions characterized with higher and higher internal complexity (also known as complex objects and complex systems). Proper use, diagnosis and renewal during operation of this class of objects by man requires extensive specialist knowledge. For this purpose, aid systems (or advisory systems) are put in place in order to assist human beings (specialists) in specified technical situations in terms of decision-making. Those aid systems develop information (diagnosis) in an automated manner (basing on their

knowledge) to help people in decision-making [8-12, 15-17].

In literature, supporting and intelligent systems are presented in detail. Such systems are used for supervision or organization of technical – technological problems in terms of their diagnosis and quality evaluation. Those systems are particularly useful when a number of variables are analyzed and it is required to consider complex factors having influence on those variables relating to: a technical condition of technical equipment, tools, manufacturing means, or selection of conditions and parameters of processes. Important achievements are brought by works of A. Birolini, W. Kacalak, and others [1-3, 8, 12]. Those works help to build up a set of conclusion rules, create knowledge representation, knowledge collection and analysis. Their works considerably help to practically solve those problems when creating expert knowledge, including its application in diagnostics or operation of technical equipment. There should be also considered works by A.H. Chister, Waterman and others in this issue since their works [3, 18-21, 29] cover mathematical background in terms of development and organization of expert systems, including rules for creation of expert knowledge bases, creation of conclusion rules and means of their analyses (look through and sort out).

In their paper, B.S. Hojjat and Shih-Lin hung, W. Kacalak, I.M. Zurada and others [8, 12, 14, 15-17, 28-31], presented a wide approach to the issue of neural networks, machine teaching of neural networks, genetic algorithms as well as sets and fuzzy knowledge. The paper includes well-developed issues of machine teaching and training of neural networks. Such problems were solved as the following: an introduction to neural networks, teaching of layered neural networks as well as teaching through competition between neurons in a network. The paper also solves in a good manner the problems of the construction and functioning of genetic algorithms. The paper covers extensively fuzzy knowledge systems, ways to represent this knowledge and to use it in the organization of artificial neural networks and expert systems.

The papers by (L. Będkowski, T. Dąbrowski, A. Rosiński and L. Pokoradi, [1, 9, 13, 21-27] presents the theoretical background of the reliability of technical devices in the operation process. The author presented mathematical basis of the policy rules of the organization of repairs (replacement of components (constructional elements)) of devices. Another important practical problem which was solved in the study is the representation of the ways and methods to set periods of repairs (replacements of functional parts) of devices and their optimization. The paper also covers preventative maintenance procedures including drawbacks of this type of maintenance.

A part of the paper deals with the issues of the development and verification of the maintenance policy strategy. The study is also of a large practical importance as regards the organization of the development of theoretical models of technical devices' maintenance processes as well as the conditions and rules of their modification.

The paper by (Duer 2010-2016) [4-12, 25], makes the use more specific (and improved) of the results of diagnostic testing in the organization of a technical object's maintenance system. The paper presents the mechanism of a negative change of states in a technical object, as a result of which there occurs in the object a reduction of its operational properties: a change of the state. The author also presented a diagram and a description of artificial neural network structures and mathematical dependencies which express the idea of the functioning of the network in compliance with the algorithm developed for it. The paper also presents theoretical grounds for diagnosing of technical objects in trivalent logic with the use of an artificial neural network. The results of the study were supported with an example of a diagnostic information database for the device tested.

Issues connected with collecting various information concerning use and operation of technical devices is still under development. Basing on bibliography review we can say that the proper choice of knowledge presentation is not fully recognized. For sure it is influenced by the choice of method of expert knowledge presentation. Structure and organization of databases for reasoning systems depends on many things, including the quality and method of data analysis. Other important factors in database development are method for reasoning and decision-making, individual properties of a given object (process) and solutions used in terms of reasoning. In technical processes and manufacturing not necessarily one method of data presentation in given smart system is present, in practice, these are very sophisticated multilayer sets of different type of information.

## 2. THE METHOD OF IDENTIFICATION ELEMENTS IN THE INTERNAL STRUCTURE OF A TECHNICAL OBJECT

The complex technical objects are functional set of components that together create a multi-dimensional dynamic system. While using such an object, it executes a qualitative utility function ( $F_c$ ) on predefined level ( $F_c \leq 1$ ), its quantity is the resultant of basic utility functions. State of the object is determined on the basis of the state of its components. Therefore determining of utility function of the object is a difficult task, because it's implicit and depends on: construction group of the components, technical state

of devices, working conditions, usage intensity, type of load etc [8, 9, 11, 12].

Controlling the quantity of qualitative utility function ( $F_c$ ) during operation requires among others description and basic knowledge about components of internal structure of the object, their type of work etc. While assigning the operational components (Fig. 1) of the object to a given class, one makes use of their following properties:

- a) function describing type of work – subset of object characteristics:

$$H = \{h_{1,1}, \dots, h_{i,j}, \dots, h_{l,j}\}. \quad (1)$$

This subset represents basic characteristic functions for implementation of which the object was created, e.x. torque, engine power, pressure in breaking system of a vehicle etc.

- b) function determining tasks performed – subset of processes:

$$L = \{l_{1,1}, \dots, l_{i,j}, \dots, l_{l,j}\}. \quad (2)$$

This subset characterizes emerging basic phenomena related to energy conversion in the object. As a result, processes of functioning of the object and task performing for which the object was created, are executed, e.x. to decrease the working temperature of engine of a vehicle the cooling system was invented.

- c) function describing the essence and type of energy conversion – subset of secondary functions:

$$M = \{m_{1,1}, \dots, m_{i,j}, \dots, m_{l,j}\}. \quad (3)$$

This subset characterizes the remaining functions reflecting secondary phenomena, that create processes participating in execution of the main task, e.x. friction between interacting parts, additional heat generation, filter plugging etc.

- d) function describing operational properties identifying given component of the object to a given class – subset of private parameters:

$$K = \{k_{1,1}, \dots, k_{i,j}, \dots, k_{l,j}\}. \quad (4)$$

This subset characterizes private parameters of components of the object, e.x. resistance, friction, elasticity, magnetic permeability etc.

- e) function determining the robustness (subset of flaws) of components in the object:

$$F = \{f_{1,1}, \dots, f_{i,j}, \dots, f_{l,j}\}. \quad (5)$$

Subset of information according to relation (4) describes highlighted robustness parameters of functional elements (components) of the object, malfunctions and damages, so it describes output of highlighted diagnostic signals in the object outside of

the permissible and limit values, e.x. constant power drop of and engine, resistance variations, elasticity drop, magnetic permeability variation etc.

The basis of the process of classification of components of operational structure of the object among the components of the H, L, M, K and F subsets is the set of characteristic properties of the elements:

$$B = \{b_s\}, \quad s = \overline{1, S}, \quad (5)$$

where:  $s$  – number of highlighted subsets of classes of the operational components.

Components in the set of operational information in form of relation (5) are the basis of the process of classification (grouping) of components of the operational structure (Fig. 1).

Of course, it is required that the elements of the  $\{b_s\}$  set include possibly big amount of data and small number of components at the same time. The  $\{b_s\}$  set is determined according to the following relation:

$$B = \{b_s \in [H \cap L \cap M \cap K \cap F]\}. \quad (6)$$

While using the relation (6) it is possible to assign the elements of operational structure of the object to one of the following subsets of their classes: I – electronic, II – mechatronic, III – electric, IV – electromechanical, V – pneumatic, VI – hydraulic, VII – mechanical, VIII – digital.

This subset characterizes the robustness parameters (private) of components of the malfunction object and their damages, in other words properties of the signals exceed their permissible and limiting values, e.x. constant power drop of engine, resistance rise, elasticity drop, magnetic permeability drop etc.

In a process of producing the expertise, which will later on be used to control the operation process of the technical object, it is important to properly classify the elements of operational structure of the object.

In order to do so, the elements of operational structure of the object are classified to the following groups:

1. **Electronic** elements, build as amplifiers, signal generators, switches, control devices, power supply devices etc. Elements of this class exhibit high robustness and they belong to a group of repairable technical devices.
2. **Mechatronic** elements are present in the state-of-the-art adjustment and control systems. They are widely used in technical devices as operated valves and actuators. Their internals include mechanical, electronic and digital devices. This group of devices is characterized by conversion of electric energy into proper kind of kinetic energy (potential) connected with displacement or rotation. Elements of this class exhibit high

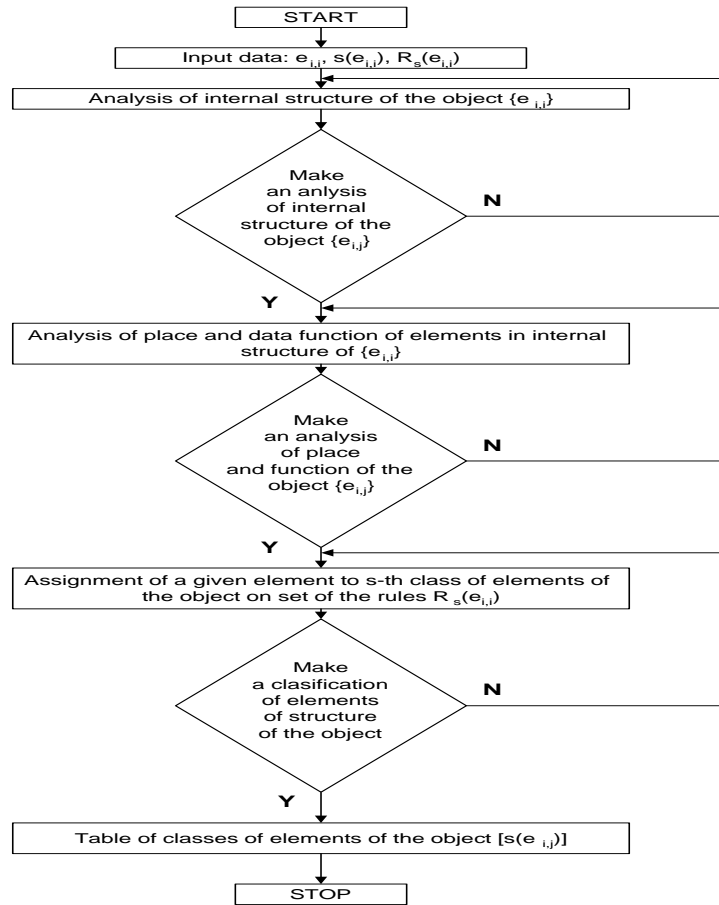

Fig. 1. Algorithm of classification of elements of operational structure of the object

- robustness and they belong to a group of repairable technical devices.
3. **Electric** elements are present as the devices connected with conversion of mechanical energy into electricity – generators, or as the devices connected with conversion of electric energy into mechanical – motors. Additionally they are used as safety and transmission elements in technical devices. This type of devices work in hard conditions: high temperatures, electromagnetic field etc. They exhibit relatively high robustness and they belong to a group of repairable technical devices.
  4. **Electromechanical** elements are placed inside technical devices as actuators, propulsion systems and operated valves. In their structure they include mechanical, electronic and other devices. Usually they are small and light. They transform into proper kind of potential energy connected with displacement or rotation. Elements of this class exhibit high robustness and they belong to a group of repairable technical devices.
  5. **Pneuma-hydraulic** elements are present in devices connected with conversion of pressure potential of fluid into proper kind of kinetic or potential energy connected with displacement or rotation. They consist of pressure tanks, control valves, electric/hydraulic actuators, transmission and safety elements. Devices in this group are small, light and they belong to a group of repairable technical devices.
  6. **Mechanical** elements, most common in technical devices as components of propulsion systems, actuators, mechanical valves, clutches and couplings. Usually they are small and light. They transform mechanical energy into proper type of kinetic (potential) energy connected with displacement or rotation. Elements of this class belong to a group of repairable technical devices.

7. **Digital** elements are present in the state-of-the-art adjustment and control systems. They consist of electric, electronic and digital devices. Elements of this class exhibit high robustness and they belong to a group of irreparable technical devices. Renewal of such elements is possible only by replacement.

The way to classify the elements of operational structure of the object is given as an algorithm (Fig. 1) and as the following relation:

$$R_s(e_{i,j}) : \text{if } (e_{i,j}) \rightarrow I \text{ to VIII then } s(e_{i,j}), \quad (7)$$

where:  $R_s(e_{i,j})$  – s-th rule of classification of operational structure for one of s-th classes of elements of the object,  $\rightarrow$  – relation of classification;  $s(e_{i,j})$  – set of classes of elements of the operational structure.

Extension of the relations (7) using supportive information presented in a form of relations (1 and 6), is a set of operational information describing rules for grouping of elements of the operational structure that is put together in Table 1.

Tab. 1. Set of rules for grouping of elements of operational structure of the object

Number of rule for grouping $\{R_s\}$	Rules for grouping of elements of operational structure of the object
$R_{s1}$	$R_1: \text{If } (e_{i,j}) \rightarrow \text{is (I – electronic)} \\ \text{Then } \{e_{i,j(I)}\}$
$R_{s2}$	$R_2: \text{If } (e_{i,j}) \rightarrow \text{is (II – mechanical)} \\ \text{Then } \{e_{i,j(II)}\}$
$R_{s3}$	$R_3: \text{If } (e_{i,j}) \rightarrow \text{is (III – electric)} \\ \text{Then } \{e_{i,j(III)}\}$
$R_{s4}$	$R_4: \text{If } (e_{i,j}) \rightarrow \text{is (IV – electromechanical)} \\ \text{Then } \{e_{i,j(IV)}\}$
$R_{s5}$	$R_5: \text{If } (e_{i,j}) \rightarrow \text{is (V – pneumatic)} \\ \text{Then } \{e_{i,j(V)}\}$
$R_{s6}$	$R_6: \text{If } (e_{i,j}) \rightarrow \text{is (VI – hydraulic)} \\ \text{Then } \{e_{i,j(VI)}\}$
$R_{s7}$	$R_7: \text{If } (e_{i,j}) \rightarrow \text{is (VII – mechanical)} \\ \text{Then } \{e_{i,j(VII)}\}$
$R_{s8}$	$R_8: \text{If } (e_{i,j}) \rightarrow \text{is (VIII – digital)} \\ \text{Then } \{e_{i,j(VIII)}\}$

Vector description of set of classes of operational structure of the object is presented in a form of the following relation:

$$[M(S)] = \{s(e_{i,j})\} = [s_1(e_{i,1}), \dots, s_l(e_{i,j}), \dots, s_L(e_{i,L})] \quad (8)$$

Results concerning grouping of elements of operational structure are presented in Table 2.

Tab. 2. Classes of elements of operational structure of the object

Level of operational structure of the object	Elements of operational structure of the object $\{M_E(e_{i,j})\}$				
	$(e_{i,1})$	...	$(e_{i,j})$	...	$(e_{i,L})$
I	$s(e_{i,1})$	...	$s(e_{i,j})$	...	$\emptyset$
⋮	⋮	...	⋮	...	⋮
i	$s(e_{i,1})$	...	$s(e_{i,j})$	...	$s(e_{i,L})$
⋮	⋮	...	⋮	...	⋮
I	$s(e_{i,1})$	...	$s(e_{i,j})$	...	$s(e_{i,L})$

where: s – classes of operational elements, where  $(s = \{I, II, \dots, VIII\})$ ,  $\emptyset$  - element supplementing the dimension of the table.

### 3. CLASSIFICATION OF THE ELEMENTS OF THE INTERNAL STRUCTURE OF A CAR ENGINE

The method for the expert knowledge base determination presented will be verified on the example of a reparable technical object, which is an analogue controller unit for combustion automotive engine with its peripheries. (Fig. 2). Research set-up was developed on the basis of a spark ignition engine with multi-point injection. The object was subject to a diagnostic development, as a result of which a functional-diagnostic diagram was developed. In the example, an object was used whose internal structure (Fig. 2) is composed of seven modules ( $E_1, E_2, \dots, E_7$ ) (Tab. 3), and each one of them, up to five elements were distinguished [4-7].

The object was subject to a diagnostic development, as a result of which the following was developed: a functional diagnostic diagram (Fig. 2 and Table 3), on the basis of which a set of maintenance elements was determined.

The presented method of diagnosing of technical objects requires the use of a uniform compliance of the designation of the elements of the object's structure. For this reason, the basic elements: modules of the object included in its functional and diagnostic model, must be "addressed" in the following manner  $(e_{i,j})$ , where: j – is the number of the element in a given assembly, and (i) is the  $i^{\text{th}}$  number of this assembly of the object.

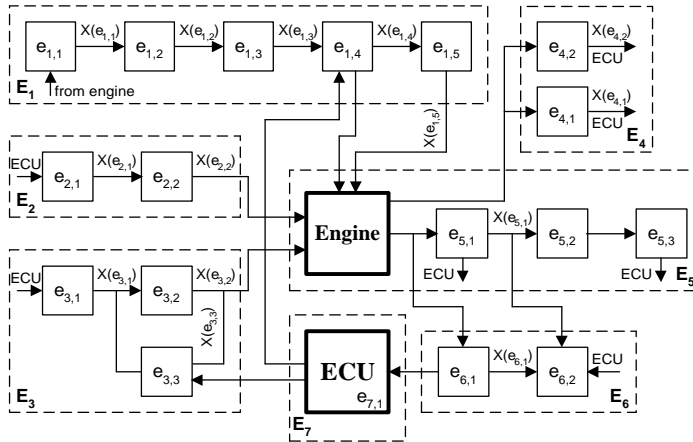

Fig. 2. Scheme of an electronic controller for an automotive engine, where:  $E_1$  – ignition module,  $E_2$  – fuelling module,  $E_3$  – air-feeding module,  $E_4$  – starting circuit,  $E_5$  – power supply circuit,  $E_6$  – engine block,  $E_7$  – electronic control unit

Tab. 3. Internal structure of the object

Assembly of the object	Structure of the object $\{e_{i,j}\}$				
$E_1$	$e_{1,1}$	$e_{1,2}$	$e_{1,3}$	$e_{1,4}$	$e_{1,5}$
$E_2$	$e_{2,1}$	$e_{2,2}$	$\emptyset$	$\emptyset$	$\emptyset$
$E_3$	$e_{3,1}$	$e_{3,2}$	$e_{3,3}$	$\emptyset$	$\emptyset$
$E_4$	$e_{4,1}$	$e_{4,2}$	$\emptyset$	$\emptyset$	$\emptyset$
$E_5$	$e_{5,1}$	$e_{5,2}$	$\emptyset$	$\emptyset$	$\emptyset$
$E_6$	$e_{6,1}$	$e_{6,2}$	$\emptyset$	$\emptyset$	$\emptyset$
$E_7$	$e_{7,1}$	$\emptyset$	$\emptyset$	$\emptyset$	$\emptyset$

where:  $E_1$  – ignition module:  $e_{1,1}$  – automotive alternator,  $e_{1,2}$  – voltage regulator,  $e_{1,3}$  – battery,  $e_{1,4}$  – coil ignition,  $e_{1,5}$  – sparking plug;  $E_2$  – fuelling module:  $e_{2,1}$  – fuel tank ventilation valve,  $e_{2,2}$  – fuel injector;  $E_3$  – air-feeding module:  $e_{3,1}$  – air flow meter,  $e_{3,2}$  – throttle position sensor,  $e_{3,3}$  – idle run position controller;  $E_4$  – starting circuit:  $e_{4,1}$  – combustion knocking sensor,  $e_{4,2}$  – coolant temperature sensor;  $E_5$  – power supply circuit:  $e_{5,1}$  – oxygen sensor (1),  $e_{5,2}$  – catalyses,  $e_{5,3}$  – oxygen sensor (2);  $E_6$  – engine block:  $e_{6,1}$  – crank shaft position sensor,  $e_{6,2}$  – EGR valve;  $E_7$  –  $e_{7,1}$  electronic control unit.

Tab. 4. Classes of operational elements of the object

Class of element $s\{e_{i,j}\}$	Elements of the assembly $\{e_{i,j}\}$						
	$E_1$	$E_2$	$E_3$	$E_4$	$E_5$	$E_6$	$E_7$
I – electronic	$e_{1,2}$	-	-	-	-	-	-
II – mechatronic	-	-	$e_{3,3}$	-	-	-	-
III – electric	$e_{1,1}; e_{1,3}; e_{1,4}; e_{1,5}$	$e_{2,1}; e_{2,2}$	-	$e_{4,1}; e_{4,2}$	$e_{5,1}; e_{5,2}$	$e_{6,1}; e_{6,2}$	-
IV – electromechanical	-	-	$e_{3,1}; e_{3,2}$	-	-	-	-
V – pneumatic	-	-	-	-	-	-	-
VI – mechanical	-	-	-	-	$e_{5,3}$	-	-
VII – digital	-	-	-	-	-	-	$e_{7,1}$

Control of the quantity of the qualitative usability function ( $F_C$ ) in the operation process requires, among other things, recognition and description of an object's internal structure, the nature of its work, etc. In modern systems for the servicing of technical objects, with a computer aided organization of this process, an important role is played in them by specialist (expert) databases [8, 10-12].

This specialist set of information concerning the object of servicing is determined on the basis of a description of the elements of the object's servicing structure, grouping of them into classes, and assigning of a specific subset of preventative activities to them, which are characteristic only of a given class of the elements of the structure (Tab. 4). For the description of the elements of the object's servicing structure for a given class, the following properties of the object and its functional elements were used. The results obtained were presented in Table 4.

On the further state of the listing (development) of the set of the object's operational information, a classification (grouping) of elements was conducted in order to distinguish classes (groups) of operational elements. With the use of the manner of classification of operational elements as presented in the article, the object's functional elements were grouped into operational classes

#### 4. CONCLUSIONS

Creating specialist databases that will support diagnosis and operation process of complex technical objects requires grouping (classification) of object elements. Thus, there is a problem of theoretical basics compilation for classification (identification) of elements in internal structure of technical object. This problem is directly connected with expert database compilation. The basis of process of elements groupings into classes of s-th subsets is to compile a model of an object presented in a form of set of basic elements of an object. Compilation of such type of diagnostic information as classification process requires wide knowledge concerning design and operation of such class of technical object as well as great experience in diagnostics. The internal structure modeling for the purpose of its diagnostics is presented in [8, 11-12].

#### References

- Będkowski, L., Dąbrowski, T. (2006). The Basis of Exploitation, Part II: The Basis of Explosional Reliability. *Military University of Technology*, Warsaw, p. 243.
- Birolini A. (1999). *Reliability Engineering Theory and Practice*. Springer, New York. p. 221.
- Christer A.H. (2002). A review of delay time analysis for modelling plant maintenance. In: *Osaki S (ed) Stochastic Models in Reliability and Maintenance*. Springer, New York. pp. 89-123.
- Duer S. (2009). Artificial Neural Network-based technique for operation process control of a technical object. *Defence Science Journal*, Vol. 59, No. 3, pp. 305-313.
- Duer S. (2010). Diagnostic system with an artificial neural network in diagnostics of an analogue technical object. *Neural Computing & Applications*, Vol. 19, No. 1, pp. 55-60.
- Duer S. (2010). Diagnostic system for the diagnosis of a repairable technical object, with the use of an artificial neural network of RBF type. *Neural Computing & Applications*, Vol. 19, No. 5, pp. 691-700.
- Duer S., Duer R. (2010). Diagnostic system with an artificial neural network which determines a diagnostic information for the servicing of a repairable technical object. *Neural Computing & Applications*, Vol. 19, No. 5, pp. 755-766.
- Duer S. (2010). Expert knowledge base to support the maintenance of a radar system. *Defence Science Journal*, Vol. 60, No. 5, pp. 531-540.
- Duer S. (2011). Modelling of the operation process of repairable technical objects with the use information from an artificial neural network. *Expert Systems With Applications*. 38, pp. 5867-5878.
- Duer S. (2012). Artificial neural network in the control process of object's states basis for organization of a servicing system of a technical objects. *Neural Computing & Applications*. Vol. 21, No. 1, pp. 153-160.
- Duer S., Zajkowski K., Duer R., Paś J. (2013). Designing of an effective structure of system for the maintenance of a technical object with the using information from an artificial neural network. *Neural Computing & Applications*. Vol. 23, No. 3-4, pp. 913-925.
- Duer S., Duer R., Mazuru S. (2016). Determination of the expert knowledge base on the basis of a functional and diagnostic analysis of a technical object. *Romanian Association of Nonconventional Technologies*, 6/2016 Vol. XX, Nr.2, pp. 23-29.
- Dhillon B.S. (2006). *Applied Reliability and Quality, Fundamentals, Methods and Procedures*. Springer – Verlag London Limited, p. 186.
- Hojjat A., Shih – Lin hung. (1995). *Machine learning, neural networks, genetic algorithms and fuzzy systems*. John Wiley End Sons, Inc, Hoboken, New Jersey, p. 398.
- Ito K., Nakagawa T. (2000). Optimal inspection policies for a storage system with degradation at periodic tests. *Math and Comput Model* 31:191-195.
- Kacalak W., Majewski M., Zurada J. M. (2010). Intelligent e-learning systems for evaluation of user's knowledge and skills with efficient information processing. *International Conference on Artificial Intelligence and Soft Computing - ICAISC 2010*, Zakopane, Poland, 13-17 June 2010. Lecture Notes in Artificial Intelligence 6114. Springer, pp. 508-515.
- Kacalak W., Majewski M. (2012). Effective Handwriting Recognition System using Geometrical Character Analysis Algorithms. *19th International Conference on Neural Information Processing - ICONIP 2012*, Doha, Qatar, 12-15 November 2012. Lecture Notes in Computer Science 7666, Part IV. Springer. pp. 248-255.
- Kaczorek T. (1994). *Matrices in automation and electrical engineering*. WNT, Warszawa. p. 254.
- Kobayashi S., Nakamura K. (2011). Knowledge compilation and refinement for fault diagnosis, *IEEE Expert*, October, pp. 39-460.
- Madan M. Gupta, Liang Jin and Noriyasu Homma (2003). *Static and Dynamic Neural Networks, From Fundamentals to Advanced Theory*. John Wiley End Sons, Inc, Hoboken, New Jersey, p. 718.
- Mathirajan M., Chandru V., Sivakumar A.I. (2007). Heuristic algorithms for scheduling heat-treatment furnaces of steel casting industries. *Sadahana*, Vol. 32, Part 5, pp. 111-119.
- Nakagawa T. (2005). *Maintenance Theory of Reliability*. Springer – Verlag London Limited, p. 264.
- Palkova Z., Okenka I. (2007). Programovanie. *Slovak University of Agriculture in Nitra*, p. 203.
- Palkova Z. (2010). Modeling the optimal capacity of an irrigation system using queuing theory. *Warszawa: Warsaw University of Life Sciences Press*. No. 55, pp. 5-11.
- Pokorádi L., Duer S. (2016). Investigation of maintenance process with Markov matrix. *Proceedings of the 4th International Scientific Conference on Advances in Mechanical Engineering*. 13-15 October 2016, Debrecen, Hungary, pp. 402-407.
- Rosiński A. (2010). Reliability analysis of the electronic protection systems with mixed – three branches reliability structure. „Reliability, Risk and Safety. Theory and Applications. Volume 3”. Editors: R. Bris, C. Guedes Soares & S. Martorell. CRC Press/Balkema, London, UK.
- Rosiński A. (2012). Reliability analysis of the electronic protection systems with mixed m-branches reliability



structure. „Advances in Safety, Reliability and Risk Management”. Editors: *Berenguer, Grall & Guedes Soares. Taylor & Francis Group*, London, UK.

28. Tang L., Liu J., Rong A., Yang Z. (2002). Modeling and genetic algorithm solution for the slab stack shuffling problem when implementing steel rolling schedules. *International Journal of Production Research*. Vol. 40, No. 7, pp. 272-276.
29. Waterman D. (1986). A guide to expert systems. *Addison – Wesley Publishing Company*, p. 545.
30. Zajkowski K. (2014). The method of solution of equations with coefficients that contain measurement errors, using artificial neural network. *Neural Computing and Applications*, Vol. 24, no. 2, pp. 431-439.
31. Zurada I. M. (1992). Introduction to Artificial Neural Systems. *West Publishing Company, St. Paul, MN*, p. 324.

### Biographical notes



**Stanisław Duer** was born in Latyczyn, Poland. He received the B.Sc. and M.Sc. degrees in electrical engineering from Military University of Technology, Warsaw, Poland. In 2003 he defended the Ph.D. thesis on technical diagnostic and received a PhD degree from Faculty of

Technology in Warsaw. Since 2003, he has been an Assistant Professor with the Electrical Engineering in Department of Energy Engineering, Faculty of Mechanics, Koszalin University of Technologies, Poland. He published sixteen books and more than 210 articles. Since 2013 he is working at the Department of Mechanics of Koszalin University of Technologies as the Professor. His areas of interest are: technical diagnostic, diagnostic systems with an artificial neural network, mathematical modelling, application of mathematical, expert systems, control theory, innovation in electronic applications in cars.



**László Pokorádi** Ph.D. C.Sc. Dr. habil., full professor of Óbuda University Institute of Mechatronics and Vehicle Engineering. Research subjects: mathematical modeling of maintenance processes; application of risk management in aviation; application of stochastic, deterministic and fuzzy models in maintenance

management; investigation of model uncertainty. **László Pokorádi** Ph.D. C.Sc. Dr.habil., full professor of Óbuda University Institute of Mechatronics and Vehicle Engineering. Research subjects: mathematical modeling of maintenance processes; application of risk management in aviation; application of stochastic, deterministic and fuzzy models in maintenance management; investigation of model uncertainty.



**Radosław Duer** was born in 1977 at Koszalin, Poland. He received the M.S. degree in electrical engineering in 2001 from the Technical University of Koszalin. Between 2002 and 2006 he was appointed as research fellow at Koszalin University of Technologies of working upon non-destructive methods for thermal investigation of thin-layer semiconductors structures. Since 2006 he is working upon electronic systems development and manufacturing for such companies as Phillips Lighting or Oticon A/S. His interest focuses on systems and processes engineering, products reliability, lifetime/fatigue investigations and thermal modelling.



**Dariusz Bernatowicz** was born in Malbork, in Poland. He received the M.S. degree in economy in 2000 and also the B.Sc and. M.S. degrees in computer engineering in 2001 from the Koszalin University of Technologies. From 2001 to 2005, he was a Software Development and Programming for multinational corporations (Java, J2EE, DBMS). Since 2005, he has been an Assistant with the Electronics and Informatics Department, Koszalin University of Technologies, Poland. His research interest includes the development and adaptation artificial neural network in the diagnostic systems of a repairable technical object, study of expert and distributed database systems and also software programming with languages Java.