

Functional and diagnostic structure of the equipment of a wind power station

Radosław DUER, Paweł WRZESIĘŃ, Stanisław DUER, Dariusz BERNATOWICZ, Ján VALÍČEK

DOI: 10.30464/jmee.2019.3.4.323

Cite this article as:

Duer R., Wrzesień P., Duer S., Bernatowicz D., Valíček J. Functional and diagnostic structure of the equipment of a wind power station. Journal of Mechanical and Energy Engineering, Vol. 3(43), No. 4, 2019, pp. 323-328.

VOLUME 3(43) | No. 4 | DECEMBER 2019 ISSN 2544-0780 | e-ISSN 2544-1671

**Journal of
MECHANICAL and ENERGY
ENGINEERING**

Editor-in-Chief
Waldemar Kuczyński

Editors
Wojciech Kapłonek | Krzysztof Nadolny

Publishing House of the Koszalin University of Technology | Koszalin 2019

Journal of Mechanical and Energy Engineering

Website: jmee.tu.koszalin.pl

ISSN (Print): 2544-0780
ISSN (Online): 2544-1671
Volume: 3(43)
Number: 4
Year: 2019
Pages: 323-328

Article Info:
Received 03 February 2020
Accepted 10 February 2020

Open Access

This article is distributed under the terms of the Creative Commons Attribution 4.0 (CC BY 4.0) International License (<http://creativecommons.org/licenses/by/4.0/>), which permits unrestricted use, distribution, and reproduction in any medium, provided you give appropriate credit to the original author(s) and the source, provide a link to the Creative Commons license, and indicate if changes were made.

FUNCTIONAL AND DIAGNOSTIC STRUCTURE OF THE EQUIPMENT OF A WIND POWER STATION

Radosław DUER¹, Paweł WRZESIEN², Stanisław DUER³, Dariusz BERNATOWICZ¹

Ján VALÍČEK⁴

^{1*} Koszalin University of Technology, Faculty of Electronics and Computer Science, Śniadeckich St.,
75-453 Koszalin, Poland, e-mail: dariusz.bernatowicz@tu.koszalin.pl, radoslaw.duer@gmail.com

² Vortex Energy Polska sp. z o.o., Department of Technical and Commercial Management, Rodła Square 8,
70-419 Szczecin, Poland, e-mail: rsc.pawel@gmail.com

³ Koszalin University of Technology, Faculty of Mechanical Engineering, 15-17 Raclawicka St.,
75-620, Koszalin, Poland, e-mail: stanislaw.duer@tu.koszalin.pl

⁴ Department of Mechanical Engineering, Faculty of Technology, Institute of Technology and Business in
České Budějovice, Okružní 10, 370 01 České Budějovice, Czech Republic, email: jan.valicek@uniag.sk,

(Received 3 February 2020, Accepted 10 February 2020)

Abstract: This article describes functional and diagnostic structure of the equipment of a Wind Power Station. Considering particular operational conditions of a technical object, that is a set of Wind Power Station equipment, this is a significant issue. A structural model of Wind Power Station equipment is developed. Based on that, a functional – diagnostic model of Wind Power Station equipment is elaborated. That model is a basis for determining primary elements of the object structure, as well as for interpreting a set of diagnostic signals and their reference signals.

Keywords: Artificial Intelligence, Expert Systems, Knowledge Base, Technical Diagnostics, Wind Power Plant

1. INTRODUCTION

Expert systems are programs that can help or replace human experts in a specific field. Such systems can provide pieces of advice, recommendations or diagnoses relating to problems appearing in a specific field [1, 2, 7-13, 16, 28]. Computer programs developed in that way are of great importance and use for fields that are poorly formalized (without having mathematical backgrounds, which could be created algorithms for) e.g. diagnostics, medicine, etc [4, 6, 22-23, 26-27]. Expert systems are characterized not only by their capability to solve non-algorithmically defined problems but also have other advantages e.g. collected expert knowledge can be easily transmitted and available if experts are not present at time (due to their sick health or retirement) and coded knowledge can be easily delivered (it is easier to copy a computer program than teach another human) and a response can be acquired fast, and there are no human symptoms like fatigue nor stress [8-13].

A problem of creating effective knowledge bases for expert systems to be used in a diagnostic process of safe usage of Wind Power Plant's equipment is considerably complex. One may say that this problem is of interdisciplinary character since it relates to e.g. IT (expert systems, knowledge bases), math (gathering and analyzing knowledge sets), diagnostic (creating models for technical models and organizing signals' measurements), reliability – operational (examining technical conditions of objects), artificial intelligence (processing and transferring human expertise into artificial knowledge using a computer programming languages) [2, 7, 10-13].

The article covers issues such as:

- making models for technical objects, including functional-diagnostic models,
- examining technical objects, including evaluation of technical condition, and creation of diagnostic signal sets,
- measuring diagnostic signals, including analysis of measurement results and creation of reference diagnostic signal sets,

- expert knowledge relating to gathering, analyzing, and concluding in an expert system,
- math problems, including creation of knowledge sets, analysis, and conclusions (making decisions).

The above-mentioned issues are not presented in literature clearly and comprehensively. Hence the diversity of the subject matter of publications used in the article. The authors of this article presented their approach to the development (solution) of such a complex problem. Such a full approach to the problem of presenting the issue of building an expert knowledge base for the purposes of diagnosing the state of safe use of wind farm equipment is an innovative solution [1, 7, 17, 20, 24-25].

This work presents the issues of building a diagnostic knowledge base for wind farm equipment. The development of a diagnostic knowledge base is the basis for building a set of facts and rules for the future expert knowledge base being built.

2. FUNCTIONAL AND DIAGNOSTIC STRUCTURE OF THE EQUIPMENT OF A WIND POWER STATION

The basis of the technical diagnostics of technical devices and items $\{O(e_{i,j})\}$ is the performance of a diagnostic test of the item examined. The diagnostic test of the item consists in a number of technical and technological activities as well as mental activities. The effect of these activities is the structure of the technical item in the form of its functional and diagnostic diagram based on which the set of the diagnostic signals $\{X_{i,j}\}$ is determined. The functional units of the item (units) in the functional and diagnostic diagram presented in Fig. 1 are "addressed": numbered in the following manner: (E_i) is the i -th number of the functional unit in the item [3-6].

The elements of the unit are "addressed" in the form $(e_{i,j})$, where j -th means the number of the element in the i -th unit. It is accepted that the j -th element or the basic module distinguished in the diagram of the structure of the item is such an element (module) of the item which is indivisible in its structure, and which develops its output signal. This

signal is further known as the measuring signal or the diagnostic signal. When the element develops more than one output signal, it is only one generalized signal that needs to be determined which expresses best the functional (diagnostic, reliability etc.) properties of a given j -th element [3-6].

The functional units are defined in the system as units and primary elements are defined as elements. Third level subunits perform the function of intermediate "elements" that enable the bidirectional transformation of the hierarchic form of the item into the matrix internal structure presented in (Tab. 1 and Figs. 2 and 3).

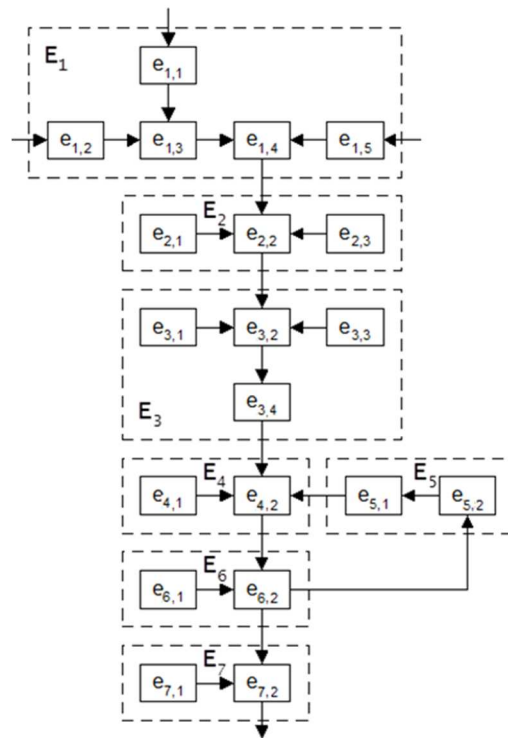

Fig. 1. Functional diagnostic diagram of a wind turbine generator, where: E1 – generator drive system, E2 – synchronous generator system, E3 – generator's magnet system, E4 – power regulator system, E5 – electric power converter system, E6 – voltage and current coordinate converter system, E7 – MV transformer assembly

Tab. 1. A set of diagnostic signals $\{X(e_{i,j})\}$ determined in a wind farm model

Object Units	A set of diagnostic signals $\{X(e_{i,j})\}$ determined in a wind farm model				
E ₁	e _{1,1}	e _{1,2}	e _{1,3}	e _{1,4}	e _{1,5}
E ₂	e _{2,1}	e _{2,2}	∅	∅	∅
E ₃	e _{3,1}	e _{3,2}	e _{3,3}	∅	∅
E ₄	e _{4,1}	e _{4,2}	∅	∅	∅
E ₅	e _{5,1}	e _{5,2}	∅	∅	∅
E ₆	e _{6,1}	e _{6,2}	∅	∅	∅
E ₇	e _{7,1}	e _{7,2}	∅	∅	∅

Where: $e_{1,1}$ – turbine shaft stabilization unit, $e_{1,2}$ – main transmission, $e_{1,3}$ – transmission temperature control system, $e_{1,4}$ – clutch, $e_{1,5}$ – generator brake, $e_{2,1}$ – synchronous generator, $e_{2,2}$ – generator temperature control system, $e_{3,1}$ – magnetic field winding, $e_{3,2}$ – system excitation voltage regulation, $e_{3,3}$ – matching system, $e_{4,1}$ – PWM inverter assembly, $e_{4,2}$ – generator power regulator, $e_{5,1}$ – controlled rectifier, $e_{5,2}$ – inverter, $e_{6,1}$ – U_A, U_B, U_C - three-phase voltage coordinate converter assembly, $e_{6,2}$ – current coordinate converter unit I_A, I_B, I_C ; $e_{7,1}$ – MV transformer temperature control system, $e_{7,2}$ – MV transformer unit.

It is assumed that the j -th basic element or basic module highlighted in the structure of the object structure is the element-module of the object that is not divisible in its structure, and which produces its output signal. The signal generated is referred to as the measuring signal or diagnostic signal. If an element generates more than one output signal, then only one generalized signal should be determined, which most closely reflects the functional (diagnostic, reliability, etc.) properties of the given j th element.

As a result of functional and diagnostic analysis, a set of measuring and reference diagnostic signals $\{X(e_i, j)\}$ was identified in the wind farm model, which are identified at the outputs of j -functional elements. The designated set of reference and measuring diagnostic signals $\{X_w(e_i, j)\}$ of a wind power plant is presented in Table 2. By analyzing

values of measurement signals, a set of reference diagnostic signals $\{X_w(e_i, j)\}$ of wind turbine generators is designated and shown in Table 2.

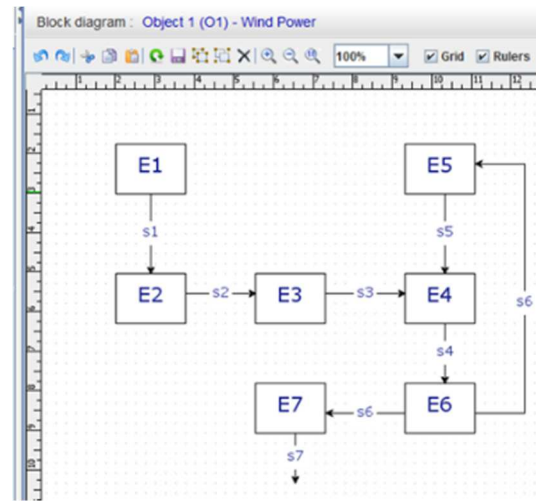

Fig. 2. Screen of (DIAG 2) programme - diagram of the functional and diagnostic structure of the wind power system, where: E1 – generator drive system, E2 – synchronous generator system, E3 – generator’s magnet system, E4 – power regulator system, E5 – electric power converter system, E6 – voltage and current coordinate converter system, E7 – MV transformer assembly

Unit	e1	e2	e3	e4	e5
E1	18	240	239	57	12,5
E2	0,0038	746	28	∅	∅
E3	38	1487	1487	1487	∅
E4	38	690	∅	∅	∅
E5	3,35	1,38	∅	∅	∅
E6	1,67	678	∅	∅	∅
E7	37	1,75	∅	∅	∅

Number signals 20 Number ∅ 15

Fig. 3. Screen of consolidated diagnostic information in (DIAG 2) software, where: E1 – generator drive system, E2 – synchronous generator system, E3 – generator’s magnet system, E4 – power regulator system, E5 – electric power converter system, E6 – voltage and current coordinate converter system, E7 – MV transformer assembly

Tab. 2. Set of measurement diagnostic signals and reference signals $\{Xw(e_{i,j})\}$ for one wind turbine generator in a Wind Power Plant as an example

Object Units		Signals of Basic Object Components	
Symbol	Description	Symbol	Description of example diagnostic signals
E ₁	Nacelle with drive train	X(e _{1,1})	Wind speed and direction measurement system - 18 reference value 18
		X(e _{1,2})	Yaw system - 240 reference value 240
		X(e _{1,3})	Drive train - 239 reference value 240
		X(e _{1,4})	Rotor - 57 reference value 60
		X(e _{1,5})	Pitch system – 12.5 reference value 13
E ₂	LSS	X(e _{2,1})	LSS stabilization system - 0.0038 reference value 0.0035
		X(e _{2,2})	LSS - 746 reference value 750
		X(e _{2,3})	LSS grease system - 28 reference value 30
E ₃	Gearbox	X(e _{3,1})	Gearbox temperature regulation system - 38 reference value 40
		X(e _{3,2})	Gearbox - 1487 reference value 1500
		X(e _{3,3})	Clutch - 1487 reference value 1500
		X(e _{3,4})	Mechanical brake - 1487 reference value 1500
E ₄	Generator	X(e _{4,1})	Generator temperature regulation system - 38 reference value 40
		X(e _{4,2})	Generator- 690 reference value 690
E ₅	Magnetizer	X(e _{5,1})	Magnetizer- 3.35 reference value 3.40
		X(e _{5,2})	Generator current regulation system - 1.38 reference value 1.40
E ₆	Converter	X(e _{6,1})	Power regulator system- 1.67 reference value 1.80
		X(e _{6,2})	Converter - 678 reference value 690
E ₇	MV Transformer	X(e _{7,1})	MV transformer – 1.75 reference value 1.80
		X(e _{7,2})	Output block - power grid – 1.75 reference value 1.80

3. CONCLUSIONS

The expert system described above that supports diagnosing wind farm devices works out an assessment of the working condition of its individual elements based on input data and a knowledge base created. Obtaining a diagnosis and the realization of the inference process takes place in an intuitive manner through the subsequent occurrence of panels that form the so-called diagnosing path. Owing to the use of a graphical interface, there is a quick access to the working condition of all the elements of the wind farm within the framework of a consolidated (general) assessment. In a detailed assessment, each element of the farm presents the working conditions of all the sub-assemblies (blocks) and the reasons of the occurrence of an alarm or failure signal. The database that is based on real measurements (the real values of diagnostic signals) and an extended knowledge base allow one to obtain a reliable diagnosis of the functioning condition of the wind farm devices. Owing to this, the expert system described can be successfully used as a part of an intelligent supervision and safety system in the operation of the wind farm.

References

1. Bernatowicz D., Duer S., Wrzesień P. (2018). Expert system supporting the diagnosis of the wind farm equipments, *Communications in Computer and Information Science*, Vol. 928, Springer, pp. 432-441.
2. Buchanan B., Shortliffe E. (1985). *Rule – Based expert systems*. Addison – Wesley Publishing Company, p. 387.
3. Duer S. (2011). Modelling of the operation process of repairable technical objects with the use information from an artificial neural network. *Expert Systems With Applications*. 38, pp. 5867-5878. <http://dx.doi.org/10.1016/j.eswa.2010.11.036>.
4. Duer S. (2012). Artificial neural network in the control process of object's states basis for organization of a servicing system of a technical objects. *Neural Computing & Applications*. Vol. 21, No. 1, pp. 153-160.
5. Duer S. (2012). Examination of the reliability of a technical object after its regeneration in a maintenance system with an artificial neural network. *Neural Computing & Applications*. Vol. 21, 3, pp. 523-534.
6. Duer S., Wrzesień P., Duer R. (2017). Creating of structure of facts for the knowledge base of an expert system for wind power plant's equipment diagnosis. *EEMS 2017, E3S Web of Conferences* 19, 01029. DOI: 10.1051/e3sconf/20171901038.
7. Hayer-Roth F., Waterman D., Lenat D. (1983). *Building expert systems*. Addison – Wesley Publishing Company.
8. Kacalak W., Majewski M. (2012). *New Intelligent Interactive Automated Systems for Design of Machine*

- Elements and Assemblies. Lecture Notes in Computer Science 7666, Part IV. Springer, 115-122.
9. Linz P. (2002). An Introduction to Formal Languages and Automata. University of California, Davis.
 10. Majewski M., Kacalak W. (2009). Intelligent e-learning system through artificial neural networks. Polish Journal of Environmental Studies. Vol. 18, 3B, Hard Publishing Company Olsztyn, pp. 237-242.
 11. Majewski M., Kacalak W. (2017). Smart Control of Lifting Devices Using Patterns and Antipatterns. Advances in Intelligent Systems and Computing, Vol. 573, Artificial Intelligence Trends in Intelligent Systems. Springer, 486-493. http://doi.org/10.1007/978-3-319-57261-1_48.
 12. Majewski M., Kacalak W. (2017). Innovative Intelligent Interaction Systems of Loader Cranes and Their Human Operators. Advances in Intelligent Systems and Computing, Vol. 573, Artificial Intelligence Trends in Intelligent Systems. Springer, 474-485. http://doi.org/10.1007/978-3-319-57261-1_47.
 13. Majewski M., Kacalak W. (2016). Building Innovative Speech Interfaces using Patterns and Antipatterns of Commands for Controlling Loader Cranes. CSCI 2016, Las Vegas, USA. IEEE Computer Society, IEEE Xplore Digital Library. 525-530. <http://dx.doi.org/10.1109/CSCI.2016.0105>.
 14. Nakagawa T. (2005). Maintenance Theory of Reliability, Springer – Verlag London Limited.
 15. Nakagawa T., Ito K. (2000). Optimal inspection policies for a storage system with degradation at periodic tests, Math. Comput. Model. Vol. 31, pp. 191-195.
 16. Palkova Z., Okenka I. (2007). Programovanie. Slovak University of Agriculture in Nitra.
 17. Pogaku N., Prodanovic M., and Green T. C. (2007). Modeling, analysis and testing of autonomous operation of an inverter-based microgrid, IEEE Trans. Power Electron, Vol. 22, 2, pp. 613-625.
 18. Pokoradi L. (2015). Logical Tree of Mathematical Modeling. Theory and Applications of Mathematics & Computer Science 5 (1), pp. 20-28.
 19. Pokorádi L., Duer S. (2016). Investigation of maintenance process with Markov matrix. Proceedings of the 4th International Scientific Conference on Advances in Mechanical Engineering. 13-15 October 2016, Debrecen, Hungary, pp. 402-407.
 20. Shahanaghi K., Babaei H., Bakhsha A. (2009). A Chance Constrained Model for a Two Units Series Critical System Suffering From Continuous Deterioration, International Journal of Industrial Engineering & Production Research. Vol. 20, pp. 69-75.
 21. Pedrycz W. (1993). Fuzzy Control and fuzzy systems. John Walley End Sons, Inc.
 22. Rosiński A. (2010). Reliability analysis of the electronic protection systems with mixed – three branches reliability structure. Reliability, Risk and Safety. Theory and Applications. Vol. 3. Editors: R. Bris, C. Guedes Soares & S. Martorell. CRC Press/Balkema, London.
 23. Rosiński A. (2012). Reliability analysis of the electronic protection systems with mixed m-branches reliability structure. Advances in Safety, Reliability and Risk Management. Editors: Berenguer, Grall & Guedes Soares. Taylor & Francis Group, London.
 24. Sanjari MJ, Gharehpetian GB. (2014). Game theoretic approach to cooperative control of distributed energy resources in islanded microgrid considering voltage and frequency stability. Neural Comput Appl 25(2):343-351. doi: 10.1007/s00521-013-1497-5.
 25. Sanjari MJ, Gharehpetian GB. (2013). Small signal stability based fuzzy potential function proposal for secondary frequency and voltage control of islanded microgrid. Electr Power Compon Syst 41(5):485-499.
 26. Siergiejczyk M., Paś J., Rosiński A. (2015). Modeling of process of maintenance of transport systems telematics with regard to electromagnetic interferences. Communications in Computer and Information Science, 531: 99-107. DOI: 10.1007/978-3-319-24577-5_10.
 27. Siergiejczyk M., Krzykowska M., Rosiński A. (2015). Reliability assessment of integrated airport surface surveillance system. Advances in intelligent systems and computing, 365: 435-443. DOI: 10.1007/978-3-319-19216-1_41.
 28. Waterman D. (1986). A guide to expert systems. Addison – Wesley Publishing Company.

Biographical notes



Stanisław Duer was born at Latyczyn in Poland. He received the B.Sc. and M.Sc. degrees in electrical engineering from Military University of Technology, Warsaw, Poland. In 2003 he defended the Ph.D. thesis on technical diagnostic and received a PhD degree from Department of Mechatronics, Military University of Technology. Since 2003, he has been an Assistant Professor with the Applied Electrical Engineering and Electronics in Department of Mechanics, Technical University of Koszalin, Poland. He published sixteen books and more than 190 articles. Since 2013 he is working at the Department of Energy in Faculty of Mechanics of Technical University of Koszalin as the Professor. His areas of interest are: technical diagnostic, diagnostic systems with an artificial neural network, mathematical modelling, application of mathematical, expert systems, control theory, innovation in electronic applications in the wind power plants equipment, cars and others.



Duer Radosław was born in 1977 at Koszalin, Poland. He received the M.S. degree in electrical engineering in 2001 from the Technical University of Koszalin. Between 2002 and 2006 he was appointed as research fellow at Technical University of Koszalin working upon non-destructive methods for thermal investigation of thin-layer semiconductors structures. Since 2006 he is working upon electronic systems development and informatics systems.



Bernatowicz Dariusz was born in Malbork, in Poland. He received the M.S. degree in economy in 2000 and also the B.Sc and M.S. degrees in computer engineering in 2001 from the Technical University of Koszalin. From 2001 to 2005, he was a Software Development and Programming for multinational corporations (Java, J2EE, DBMS). Since 2005, he has been an Assistant with the Electronics and Informatics Department, Technical University of Koszalin, Poland. His research interest includes the development and adaptation artificial neural network in the diagnostic systems of a repairable technical object, study of expert and distributed database systems and also software programming with languages Java.



Wrzesień Paweł was born in 1987 at Darłowo, Poland. He received the B.Sc. degree in power engineering in 2016 from the Technical University of Koszalin and has been expecting the M.Sc. degree in electric power engineering in 2018 from the Wrocław University of Science and Technology.

From 2012 to 2015 he worked as operations & maintenance manager of wind farms. Since 2015 he has been Head of Technical and Commercial Management of Wind and PV assets at vortex energy, managing the assets in Poland and Germany. His areas of interest are: optimization of operations and maintenance of wind and PV parks, technical diagnosis, development and application of the AI in expert systems for operational safety and reliability of wind and PV parks interconnected to respective DSOs.



Ján Valiček graduated from the Faculty of Mining and Geology, Technical University of Ostrava in 2000. He received his PhD and DSc degrees in 2004 and 2008, respectively. Currently he works as an professor in Department of Mechanical Engineering, Faculty of Technology, Institute of Technology and Business

in České Budějovice, (České Budějovice, Czech Republic) and also in Department of Electrical Engineering, Faculty of Engineering, Slovak University of Agriculture in Nitra, Automation and Informatics (Nitra, Slovakia). He specializes in characterization, processing and measurements of modern materials, metallurgical engineering as well as advanced technological processes. He was awarded by four prizes of Werner von Siemens Excellence Award for the best research works in 2001 for scholarship support for student, in 2005 for the best PhD. He published over 150 scientific papers.